

RAYPA

Leading
Lab Technologies

 Sterilization

VERTICAL AUTOCLAVES WITH DRYING

AE-DRY SERIES **CLASSIC LINE**

ECONOMIC, COST-EFFECTIVE,
ROBUST PERFORMANCE
AND LIMITED LABORATORY
RESOURCES CONSUMPTION



Vertical autoclaves with drying

The **AE-DRY** Series vertical floor-standing autoclaves with top-loading access cover most laboratory sterilization needs in many industries, educational institutions and research facilities with the aim of increasing the productivity of the laboratory. A great chamber capacity, the final drying feature and the independent water tank together with the optimization of resources such as water, power and operating time results in an affordable and very cost-effective solution to manage laboratory workload.

INTENDED USE

+ **STERILIZATION OF LABORATORY WASTE BAGS, PLASTICS, CULTURE MEDIA, GLASSWARE, LIQUIDS, ITEMS OF COMPLEX GEOMETRIES AND SMALL POROUS OR HOLLOW OBJECTS**



MAIN FEATURES

COST-EFFECTIVE SOLUTION

AE-DRY Series autoclaves are robust autoclaves with excellent performance for liquids and solids sterilization procedures. The final vacuum drying feature by a heating jacket and a vacuum pump at the end of the sterilization cycle eliminates the need of an external equipment to dry the load, significantly reducing the duration of each sterilization procedure rotation and saving operator time.

MULTIPLE TYPES OF STERILIZATION CYCLES

Several options available to perform solids or liquids sterilization. Programmable final vacuum drying for the sterilization of solids, initial prevacuum for the sterilization of items of complex geometries and programmable temperature holding at the end of the cycle for the sterilization of culture media. Optional flexible temperature probe for load sensed sterilization of liquids.

EASY INSTALLATION AND MAINTENANCE

Every **AE-DRY** Series autoclave is a plug and play equipment that does not need dedicated installation connections. They simply need a power source and can work even without a connection to the drainage. They include a manually fed independent water tank that automatically feeds the sterilization chamber with an optional upgrade to fully automatic water feed directly from water network. They also include casters so they can be used in different areas of the same facility.

SAFETY FIRST

AE-DRY Series autoclaves are equipped with several features to ensure the safety of the operators. These include an overpressure safety valve, a thermally insulated door, an overtemperature safety thermostat, a water level detector, an open door detection system and an independent safety pneumatic system that locks the main door while positive pressure exists inside the sterilization chamber.



ADVANTAGES



Final vacuum drying feature by a heating jacket and vacuum pump to completely dry solid loads.



Sterilization chamber and door made of high quality stainless steel grade AISI-316L extremely resistant to corrosion.



Equipment built following all applicable European Union quality, regulatory and safety standards.



Heating by powerful electric elements made of Incoloy® 825 assembled inside the sterilization chamber and shielded by a protective grid.



Control by a PID microprocessor with 4 predefined and 6 editable programs, adjustable by time, temperature, drying time and type of sterilization cycle (solids or liquids, with optional Agar mode and/or heart probe control).



Available special models with augmented power to achieve faster heating and sterilization phases.



Suitable to sterilize wrapped and unwrapped loads, small porous and hollow objects and items of complex geometries with cavities thanks to the standard initial prevacuum phase*.



Automatic water feed to the sterilization chamber from the independent water tank, with water level sensors included in both locations. Optional upgrade to fully automatic water feed directly from water network.



Adjustable temperature holding at the end of the sterilization cycle between 40-80°C (Agar mode).



Programmable auto-start for up to 24h.



Optional software for sterilization data management.



Optional integrated or external printer.



Plug and play equipment, no plumbing required.



Easy mobility, all models include casters.



STERILIZATION APPLICATIONS

AE-DRY Series autoclaves are intended for the sterilization of a wide range of liquids and solids such as culture media, glassware, plastics, metal utensils, laboratory waste bags and other laboratory items.

Furthermore, thanks to the standard initial prevacuum pulse and the fractioned postvacuum with drying, **AE-DRY** Series autoclaves are also suitable to sterilize wrapped and unwrapped solids, small porous and hollow objects*.

***AE-DRY** Series autoclaves may not be suitable for these applications if the chamber is heavily loaded. In these circumstances, **AE-B** Series autoclaves should always be used. In case of doubt, please contact us and our team will offer expert guidance.

Vertical autoclaves with drying

WORKING PRINCIPLE

AE-DRY Series autoclaves provide a solution for the multiple sterilization needs of general laboratories including glassware, plastics, metal utensils, laboratory waste bags, wrapped and unwrapped solids, small porous and hollow objects, liquids, culture media and other laboratory items.

The load has to be placed into the vessel's baskets and, after manually filling the independent water tank with purified water, the equipment starts to create the initial prevacuum, automatically feeds water to the sterilization chamber, heats up and purges until the set combination of sterilization time and sterilization temperature is reached.

DIGITAL MICROPROCESSOR

Digital microprocessor with 6 push-buttons for an easy programming and parameters selection.

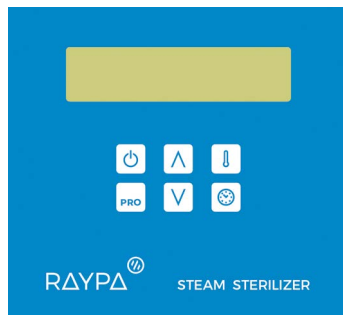

AE-DRY SERIES PROGRAMS

AE-DRY Series autoclaves have 10 programs, from P0 to P9, and the first four are predefined and protected.

PREDEFINED PROGRAMS

Program N°	Sterilization temperature °C	Sterilization time min	Drying time min	Program mode Solids, Liquids or Agar	Heart probe regulation
P0	115	60	12	Solids	-
P1	121	30	25	Solids	-
P2	133	20	30	Solids	-
P3	121	20	-	Liquids	-

The rest of the programs are editable with the following parameters settings:

- Sterilization temperature.
- Sterilization time.
- Final drying time.
- Sterilization mode (solids or liquids).
- Sterilization with temperature holding at the end of the cycle (Agar mode).
- Sterilization controlled by main chamber temperature probe or both main chamber temperature probe plus heart temperature probe.

STANDARD AE-DRY SERIES STERILIZATION CYCLE

PREVACUUM PHASE

- In this initial step, the equipment's vacuum pump mechanically removes air from the chamber and load through a single vacuum pulse of -0,75 Barg. This allows the steam to penetrate load objects of difficult geometries that couldn't otherwise be reached with simple gravity displacement.
- Afterwards, the independent water tank starts to feed water to the sterilization chamber and the heating jacket is turned on, preheating the load.

HEATING PHASE

- After completing the prevacuum phase and once the sterilization chamber bottom is filled with water, the powerful heating elements assembled at the bottom of the sterilization chamber heat up dramatically, transferring energy to water to produce saturated steam throughout the chamber.
- To shorten the duration of this step, RAYPA offers special models with increased power, a feature of particular interest for autoclaves operating in laboratories with high workloads.

STERILIZATION PHASE

- Upon reaching the set sterilization temperature inside the chamber the sterilization phase begins, accurately sustaining the temperature throughout the duration of this phase.
- This crucial step is controlled by a PT-100 Class A temperature probe located within the chamber. As an option for liquids sterilization processes, this phase can be regulated by a flexible PT-100 Class A temperature probe located inside a sample.

VACUUM DRYING PHASE

- After sterilization phase finishes, only for solid programs, vacuum drying starts,

where multiple vacuum pulses occur while the heating jacket is turned on, completely drying the load and automatically feeding back the water to the independent water tank.

COOLING PHASE

- After the vacuum drying step is completed natural cooling begins and an acoustic beep will sound when a safety temperature is reached and the door can be opened.
- In liquid programs with Agar mode activated, the equipment will hold the preprogrammed temperature indefinitely, selectable between 40 and 80°C.

Sterilization cycle graph for a solid load

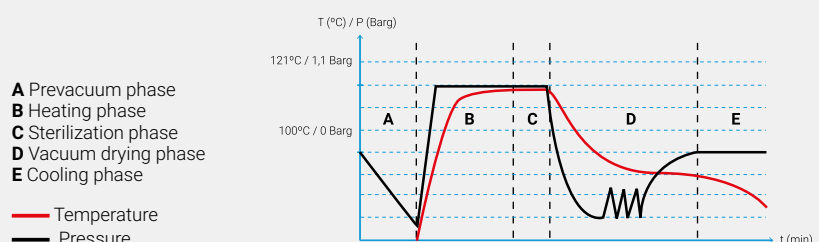



FUNCTIONS DISPLAYED BY THE ALPHANUMERIC LCD SCREEN

The alphanumeric screen apart from showing the standard sterilization parameters also shows current sterilization phase and several visual alerts, including warning or failure messages. The available languages include English, Spanish, French and Catalan. For other languages please contact us.

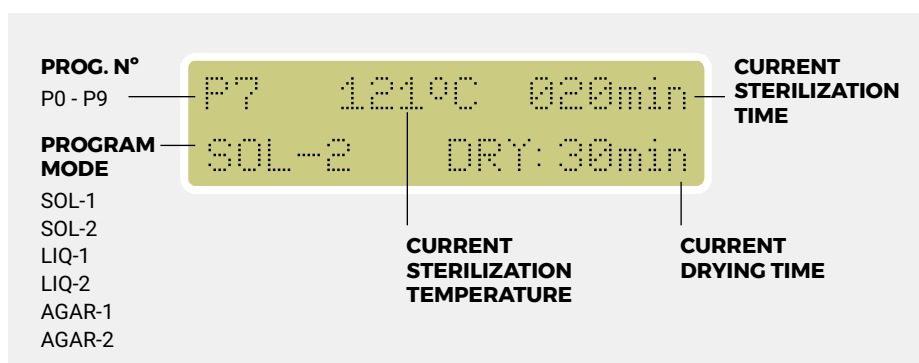

LOADING CAPACITIES



ERLENMEYER FLASKS

Autoclave model	AE-28-DRY	AE-50-DRY	AE-75-DRY	AE-110-DRY	AE-150-DRY	
Usable chamber dimensions Ø x H mm	300 x 440	300 x 710	400 x 600	400 x 850	500 x 780	
Usable capacity L	31	50	75	110	153	
250 ml (Ø 85 x 143 mm)	Total baskets	2	3	3	4	4
	Total units per basket	7	7	12	12	20
	Total units	14	21	36	48	80
500 ml (Ø 105 x 183 mm)	Total baskets	2	3	2	3	4
	Total units per basket	4	4	8	8	14
	Total units	8	12	16	24	56
1000 ml (Ø 131 x 230 mm)	Total baskets	1	1	2	3	3
	Total units per basket	1	1	4	4	8
	Total units	1	1	8	12	24
2000 ml (Ø 166 x 280 mm)	Total baskets	1	1	1	1	1
	Total units per basket	1	1	3	3	5
	Total units	1	1	3	3	5



BOTTLES

Autoclave model	AE-28-DRY	AE-50-DRY	AE-75-DRY	AE-110-DRY	AE-150-DRY	
Usable chamber dimensions Ø x H mm	300 x 440	300 x 710	400 x 600	400 x 850	500 x 780	
Usable capacity L	31	50	75	110	153	
250 ml (Ø 70 x 143 mm)	Total baskets	2	3	3	4	4
	Total units per basket	10	10	19	19	30
	Total units	20	30	57	76	120
500 ml (Ø 86 x 182 mm)	Total baskets	2	3	2	3	4
	Total units per basket	7	7	12	12	20
	Total units	16	24	24	36	80
1000 ml (Ø 101 x 203 mm)	Total baskets	1	1	2	3	3
	Total units per basket	2	2	8	8	14
	Total units	2	2	16	24	42
2000 ml (Ø 136 x 260 mm)	Total baskets	1	1	1	1	1
	Total units per basket	1	1	4	4	8
	Total units	1	1	4	4	8

*All data on loading capacities of these tables are non-binding guidance to help you choose your autoclave model. The total units per basket and per model have been calculated using standard baskets, for special loads that require custom baskets please contact us.

Vertical autoclaves with drying

Accessories



INTEGRATED BASKETS CRANE

Reference	ELEV-CLAV
Dimensions L x D x H mm	800 x 300 x 2100
Power W	480
Weight Kg	40
For autoclaves with the following chamber volumes L	79, 115 and 175
Max. load Kg	30
Voltage V	230
Frequency Hz	50/60

*Must be installed in our facilities.

Intended use

- Powerful lift system with adjustable arm to assist the movement of heavy loads into the autoclave.

Features

- Ease of use.
- Compatible with 79L, 115L and 175L vertical autoclaves. Contact us for other models.
- Up to 200 degrees of rotation.

Safety

- Emergency stop button.
- Motor with auto braking system.

MOBILE BASKETS CRANE

- Electrically operated crane made of stainless steel to assist the loading and unloading of heavy loads up to 50 Kg.
- Push-button operation control for ease of use.
- With swiveling casters for more maneuverability.

Reference: **MOB-LIFT**

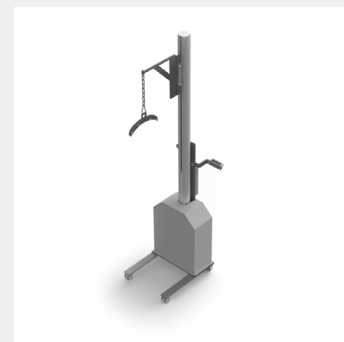



Accessories

STAINLESS STEEL WIRE BASKETS

Reference		CV-28	CV-75S	CV-75	CV-150S	CV-150M
Dimensions	Exterior Ø x H mm	270 x 185	370 x 180	370 x 265	470 x 190	470 x 235
	Interior Ø x H mm	260 x 180	360 x 175	360 x 260	460 x 185	460 x 230
For autoclaves with the following chamber volumes	33 L	2	-	-	-	-
	55 L	3	-	-	-	-
	79 L	-	3	2	-	-
	115 L	-	4	3	-	-
	175 L	-	-	-	4	3



STAINLESS STEEL LIQUIDS COLLECTOR TRAY FOR WIRE BASKETS

Reference		TR-270	TR-370	TR-470
Dimensions	Exterior Ø x H mm	240 x 50	320 x 50	420 x 50
	Interior Ø x H mm	238 x 48	318 x 48	418 x 48
For the following wire baskets models	CV-28	✓	-	-
	CV-75S & CV-75	-	✓	-
	CV-150S & CV-150M	-	-	✓



UNPERFORATED STAINLESS STEEL BASKETS FOR LABORATORY WASTE STERILIZATION

Reference		CCI-28	CCI-75S	CCI-75	CCI-150S	CCI-150M
Dimensions	Exterior Ø x H mm	270 x 185	370 x 180	370 x 265	470 x 190	470 x 235
	Interior Ø x H mm	260 x 180	360 x 175	360 x 260	460 x 185	460 x 230
For autoclaves with the following chamber volumes	33 L	2	-	-	-	-
	55 L	3	-	-	-	-
	79 L	-	3	2	-	-
	115 L	-	4	3	-	-
	175 L	-	-	-	4	3



STAINLESS STEEL "SCHIMMELBUSCH" DRUM FOR MEDICAL INSTRUMENTS STERILIZATION

Reference		TBE-24x16	TBE-34x24	TBE-48x24
Dimensions	Exterior Ø x H mm	240 x 165	340 x 240	480 x 240
	Interior Ø x H mm	230 x 155	330 x 230	470 x 230
For autoclaves with the following chamber volumes	33 L	2	-	-
	55 L	4	-	-
	79 L	-	2	-
	115 L	-	3	-
	175 L	-	-	3



Vertical autoclaves with drying

Accessories

STAINLESS STEEL CYLINDERS FOR PETRI DISHES STERILIZATION

Reference		CEP-1027	CEP-1041	CEP-1427	CEP-1441	
Dimensions	Exterior Ø x H mm	100 x 270	100 x 410	140 x 270	140 x 410	
	Maximum number dishes / cylinder	10	18	10	18	
Petri dishes	Diameter Ø mm	80	80	120	120	
	For autoclaves with the following chamber volumes	33 L	4	4	2	2
		55 L	8	4	4	2
		79 L	16	8	10	5
		115 L	24	16	15	10
		175 L	28	14	16	8



STAINLESS STEEL CYLINDERS FOR PIPETTE STERILIZATION

Reference		CEPP-726	CEPP-740	CEPP-1025	CEPP-1435	
Dimensions	Exterior Ø x H mm	70 x 260	70 x 400	100 x 250	140 x 350	
	Interior Ø x H mm	60 x 250	60 x 390	90 x 240	130 x 340	
For autoclaves with the following chamber volumes		33 L	11	11	6	6
		55 L	22	11	12	12
		79 L	42	21	20	10
		115 L	63	42	30	20
		175 L	90	30	51	34



STAINLESS STEEL TRAY SUPPORT WITH HEIGHT ADJUSTABLE TRAYS*

Reference		SRA-1	SRA-5	SRA-2	SRA-3	SRA-4	SRA-2-3	SRA-4-3
Dimensions Ext. Ø x H mm		270x390	270x680	370x560	370x810	470x740	370x190	470x250
	Max. number trays/support	8	14	11	16	15	4	5
Trays	Ref.	TSRA-1/5	TSRA-1/5	TSRA-2/3	TSRA-2/3	TSRA-4	TSRA-2/3	TSRA-4
	Dim. Ø x H mm	252x20	252x20	356x20	356x20	454x20	356x20	454x20
For autoclaves with the following chamber volumes		33 L	1	-	-	-	-	-
		55 L	-	1	-	-	-	-
		79 L	-	-	1	-	-	3
		115 L	-	-	-	1	-	4
		175 L	-	-	-	-	1	-



BSRA
Set of 30 individual
fastening clips.

*The purchase of a tray support includes a set of 3 trays and 9 fastening clips. Likewise, the purchase of a tray includes a set of 3 fastening clips.



Accessories

FLEXIBLE “HEART” TEMPERATURE PROBE PT-100 CLASS A

- After installing this accessory, the temperature regulation of the sterilization cycle can either be controlled by the main chamber temperature sensor or both the main chamber temperature sensor and the temperature sensor of the flexible heart temperature probe.
- The temperature control by the flexible heart temperature probe is especially advantageous for processes involving the sterilization of large volumes of liquids, where the sterilization process is regulated by both the temperature achieved in the center of the liquid sample as well as the temperature achieved in the sterilization chamber. Furthermore, should the autoclave be opened at chamber temperatures higher than 80°C there is a risk of liquids boiling over which can be avoided if the temperature of the sample is controlled throughout the sterilization procedure.
- Must be installed in our facilities.

Reference: **PT-2**



EXTERNAL TEMPERATURE PROBE ADAPTER



- External adapter for continuous validation processes that allows the access of an external probe (Ø 3-6 mm) to obtain a temperature reading independent from that of the equipment microprocessor.
- It is located on the door of the autoclave.
- Must be installed in our facilities.

Reference: **EXT-TP**

INTEGRATED THERMAL PRINTER

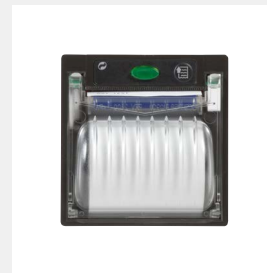

- Prints program number, cycle number, temperature, date and hour of the run and error messages.
- Selectable printing cadence between 10 and 240 seconds.
- Must be installed in our facilities.

Reference: **IT**

Consumable:

Paper: **PAPER-IT**

TABLE TOP DOT MATRIX PRINTER



- Prints program number, cycle number, temperature, date and hour of the run and error messages.
- Used with RS-232 connection.
- Selectable printing cadence between 10 and 240 seconds.

Reference: **ITS**

Consumables:

Paper: **PAPER-ITS**, Ribbon: **70945**

INTEGRATED DOT MATRIX PRINTER



- Prints program number, cycle number, temperature, date and hour of the run and error messages.
- Selectable printing cadence between 10 and 240 seconds.
- Must be installed in our facilities.

Reference: **IT/M**

Consumables:

Paper: **PAPER-ITS**, Ribbon: **70934**

PREMIUM CASTERS (2 WITH BRAKES)



- Although all AE-DRY Series autoclaves include casters, this accessory offers the option of upgrading them with a more resistant and higher quality casters that include brakes.
- Enables an easier movement of the equipment.
- Must be installed in our facilities.

Reference: **4WHBR**

Vertical autoclaves with drying

Accessories

SW7000 SOFTWARE



- Communication software between the equipment and the PC that allows the real-time and posterior visualization and registry of each cycle. Cycles can also be exported to Excel or printed.
- Connection to PC via RS-232.
- Supplied with a RS-232 cable, an USB stick that includes the software and installation drivers and a RS-232 to USB adapter.

Reference: **SW7000**

TRANSPORT TROLLEY



- Auxiliary trolley to assist the loading and unloading of the autoclave.
- Built in chromed iron and plastic.
- The surface of each shelf is textured to prevent the load from shifting.
- Rubber coated wheels to reduce noise.
- Dimensions (LxDxH): 730 x 490 x 700 mm.

Reference: **TR-TR**

STERILIZATION CONTROL TAPE

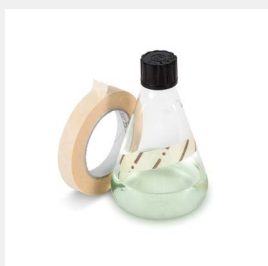

- Class 1 indicator for steam sterilization. The change of color indicates that the materials have been processed, without being a guarantee of proper sterilization, additional methods are needed such as biological indicators (EN ISO 11138).
- Tape roll of 50 m x 19 mm.

Reference: **TEST-CT**

20 min 121°C
Color change.

CABLE GLANDS



- Installation of up to 8 cable glands within the sterilization chamber walls to enable external temperature probe access in multiple locations for autoclave calibration and validation procedures.
- These ports can either be of 2 or 4 mm of diameter.

References:

PRENSACLAV (8 holes \varnothing 2mm),
PRENSACLAV2 (8 holes \varnothing 4mm).

AUTOMATIC WATER FILLING KIT



- Water pump to automate the feed of the independent water tank with purified water.
- Compatible with installations that either have a purified water network, a purified water tank or facilities that have an unpurified water network, in the latter case, the kit should be supplied with two other accessories: water purifier (ECOPUR-500) and purified water tank (TANK-KLL).
- Must be installed in our facilities.

Reference: **KLL**

ECO-EFFICIENT WATER PURIFIER



- Direct flow eco-efficient water purifier without water accumulation capable of filtering 1,3L/min with LED display.
- The installation of this accessory requires the joint installation of the external tank (TANK-KLL) and the automatic water filling system (KLL) corresponding to each model.

Reference: **ECOPUR-500**

Exterior dimensions L x D x H mm	Purity (TDS) ppm	Electrical conductivity μ S	Hardness mmol/l
220 x 425 x 415	0,0005	>1	0,0125



TECHNICAL SUMMARY OF AE-DRY SERIES AUTOCLAVES

General classification	Recommended setting	General laboratory
	Equipment placement	Floor-standing
	Load direction	Top-loading
	Chamber profile	Round
Recommended type of load	Liquids and culture media	✓
	Laboratory waste bags	✓✓
	Glassware	✓✓
	Plastics	✓✓
	Wrapped, unwrapped and small porous objects	✓
Sterilization technology features	Method to generate steam	Heating elements
	Type of purge	Vacuum
	Vacuum drying by heating jacket and vacuum pump	✓
Transfer of data	RS-232	✓
Batch printers	Integrated printer	○
	External printer	○
Sterilization chamber and door specifications	Sterilization chamber volume	33 - 175 L
	External building material	AISI-304
	Sterilization chamber material	AISI-316L
	Heating elements material	Incoloy® 825
	Gasket material	Silicone rubber
	Min.- max. sterilization temperature	100 - 134°C
	Maximum pressure (above atmospheric pressure)	2,1 Barg
	Mechanism to open the door	Manual wheel
	Direction in which the door opens	Lateral
	Automatic locking with pressure	✓
Thermally insulated door	✓	
User interface and microprocessor	Screen display	Digital LCD
	Screen size	2 lines x 16 digits
	Total number of available programs	10
	Automatic microprocessor control	✓
	Timer start	✓
Special cycles and process optimization	Agar mode (temperature holding after cycle ends 40-80°C)	✓
	Final postvacuum drying (to completely dry solid loads)	✓
	Temperature regulation by heart probe	○
Adjustable cycle parameters	Agar mode	40 - 80°C
	Temperature of sterilization phase	100 - 134°C
	Duration of sterilization phase	1 - 250 min
	Duration of drying phase	3 - 99 min
	Temperature regulation by heart probe	On/Off
	Sterilization mode (solids or liquids)	✓
Other specifications	Air intake with bacteriological filter	✓
	Independent water tank capacity	9 - 20 L
	Flexible heart temperature probe	○
	Standard casters	✓
	Premium casters with brakes	○
	Pressure gauge	✓
	Electric customization (115-230M V/230-400T V)	○
Special models with augmented power	○	
Services	Third-party qualification (IQ/OQ/PQ)	○

✓: Standard ○: Optional

TECHNICAL DATA

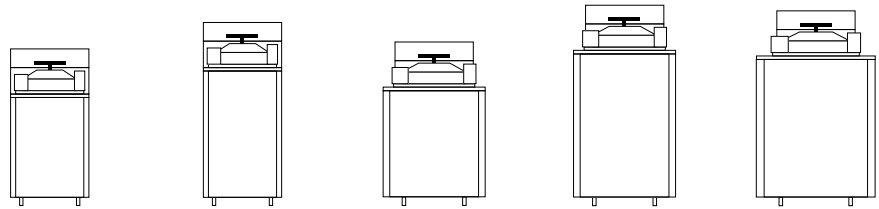

Specifications

Reference	AE-28-DRY	AE-50-DRY	AE-75-DRY	AE-110-DRY	AE-150-DRY
Total/usable chamber volume L	33/31	55/50	79/75	115/110	175/153
Usable chamber dimensions Ø x H mm	300 x 440	300 x 710	400 x 600	400 x 850	500 x 760
Independent water tank volume L	9	9	12	12	20
Exterior dimensions L x D x H mm	505 x 580 x 1110	505 x 580 x 1290	610 x 700 x 1185	610 x 700 x 1435	750 x 820 x 1400
Loading height mm	795	975	870	1120	1085
Power W	2000 or 3200	3200 or 6000	3200 or 6000	4500, 6000 or 9000	6000 or 9000
Gross weight Kg	90	110	140	180	265
Voltage* V	230V (1P+N) 16A	230V (1P+N) 16A	230V (1P+N) 16A or 400V (3P+N) 32A	400V (3P+N) 32A	400V (3P+N) 32A
Frequency Hz	50/60	50/60	50/60	50/60	50/60

*Other voltages available under request. Special models with augmented power may operate with other voltages.

Safety features

- Safety valve.
- Safety thermostats with manual rearm for the heating jacket and the heating elements.
- Pneumatic door blocking system while positive pressure exists inside the sterilization chamber.
- Open door sensor.
- Thermally insulated door.
- Water level detector in the sterilization chamber.
- Water level detector (min./max.) in the independent water tank with overflow drainage.
- Bacteriological filter for inlet air.
- Heating elements cover.
- Several visual and acoustic safety and warning alarms.

Regulations

All our AE-DRY Series autoclaves are designed to comply with the strictest international directives and standards, including the following regulations:

- **EN-61010-1** Safety requirements for electrical equipment for measurement, control and laboratory use. Part 1: General requirements.
- **EN-61010-2-040** Part 2-040: Requirements for laboratory autoclaves.
- **EN-61326** Electrical equipment for measurement, control and laboratory use. EMC requirements.
- **AD 2000 Merkblatt** Pressure vessels.
- **2014/35/UE** Low voltage.
- **2014/30/UE** Electromagnetic compatibility.
- **2014/68/UE** Pressure equipment.

General features

Adjustable sterilization temperature	100 - 134°C
Adjustable sterilization time	1 - 250 min
Adjustable drying time	3 - 99 min
Max. pressure	2,1 Barg
Sterilization control system	Fully automatic microprocessor control by either chamber temperature probe or flexible heart temperature probe
Air purge system	Mechanical displacement by vacuum pump
Vacuum drying system	Vacuum pump plus heating jacket
External building material	AISI-304 stainless steel
Single prevacuum pulse system	Vacuum pump
Sterilization chamber material	AISI-316L stainless steel
Heating elements material	Incoloy® 825
Gasket material	Silicone rubber
Connection to PC	RS-232
Connection to printer	RS-232 or integrated
Number of programs	10 (4 preset and 6 user free)
Programmable auto-start	Up to 24 h
Screen type	LCD display
Opening door mode	Horizontal swiveling door with blocking wheel
Monitoring of sterilization parameters	Self-control of obtained values (T° & t) vs programmed values. Cycle is automatically interrupted if obtained values differ from programmed values
Pressure display	Pressure gauge on control panel
Water management	Independent manually fed water tank that automatically feeds the sterilization chamber. Water returns automatically to the independent water tank after cycle is completed. Optional upgrade to fully automatic water feed directly from water network
Drainage system	A drainage connection and a manual valve for overflow and drainage of the independent water tank and a screw to manually clean the drainage filter and drain the sterilization chamber
Casters	Included standard casters, optional upgrade to premium casters with brakes

+ info

YouTube

CLICK!
ACCESS
THE AE-DRY
SERIES
VIDEO

Find out more about our **AE-DRY Series autoclaves** on our **Youtube Channel**

Installation guide available under request, please contact us.



REV 06.2021